

IRSN

INSTITUT
DE RADIOPROTECTION
ET DE SÛRETÉ NUCLÉAIRE

Evaluation of PEGASOR PPS™ response time for real time aerosol concentration measurements

F. Gensdarmes⁺, A. Roynette⁺, D. Maro⁺,
P. Laguionie⁺, D. Boulaud⁺ and J. Tikanen^{*}

+ IRSN

* PEGASOR

Outline

1 - Context and objectives

- Needs of real time aerosol measurement for application of Eddy covariance method
- The PPS, a new promising fast aerosol sensor

2 - Experimental method and data treatment

- Concentration step method and experimental set-up

3 - Results on PPS response time

- Measurement at 10 Hz and 100 Hz
- Influence of sampling lines

4 - Results on PPS linearity versus CPC and data analysis

- Raw data
- Data analysis versus aerosol surface area concentration

5 - Conclusion and perspectives

Context and objectives

Measuring and understanding aerosol deposition velocity in the environment is a challenge for predicting the transfer of airborne contaminants

⇒ The Eddy covariance method for aerosol deposition measurement is under development at IRSN (Ph.D. Pierre Damay, Damay *et al.* (2009) *J. Aerosol Sci.*)

⇒ The Eddy covariance method requires to measure wind speed fluctuations and aerosol concentration fluctuations

$$w = w' + \bar{w}$$

Wind speed = fluctuation + mean value

$$c = c' + \bar{c}$$

Aerosol concentration = fluctuation + mean value

$$Vd = \frac{-F}{\bar{c}} = \frac{-\overline{w'c'}}{\bar{c}}$$

Aerosol deposition velocity Vd is calculated from covariance between w' and c'

$w'c' > 0$ for emission flux
 $w'c' < 0$ for deposition flux

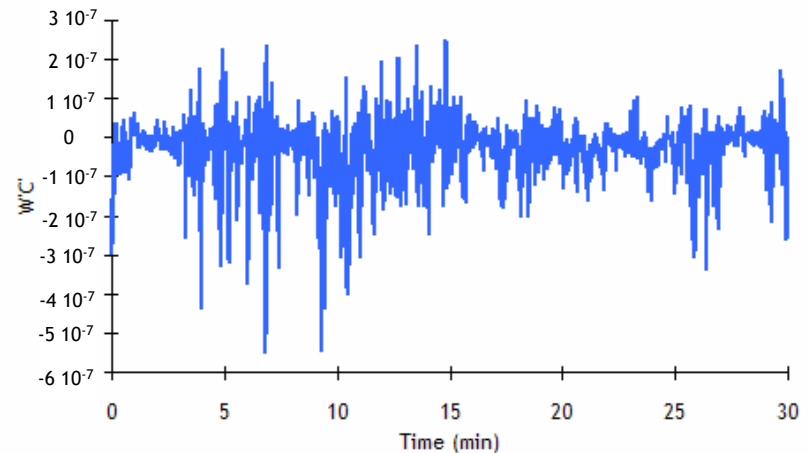

Context and objectives

Classical experimental set-up for application of Eddy covariance method (PhD. Damay)

=> measurement of wind fluctuations with an ultrasonic anemometer

=> measurement of size resolved aerosol concentration fluctuations with an outdoor ELPI

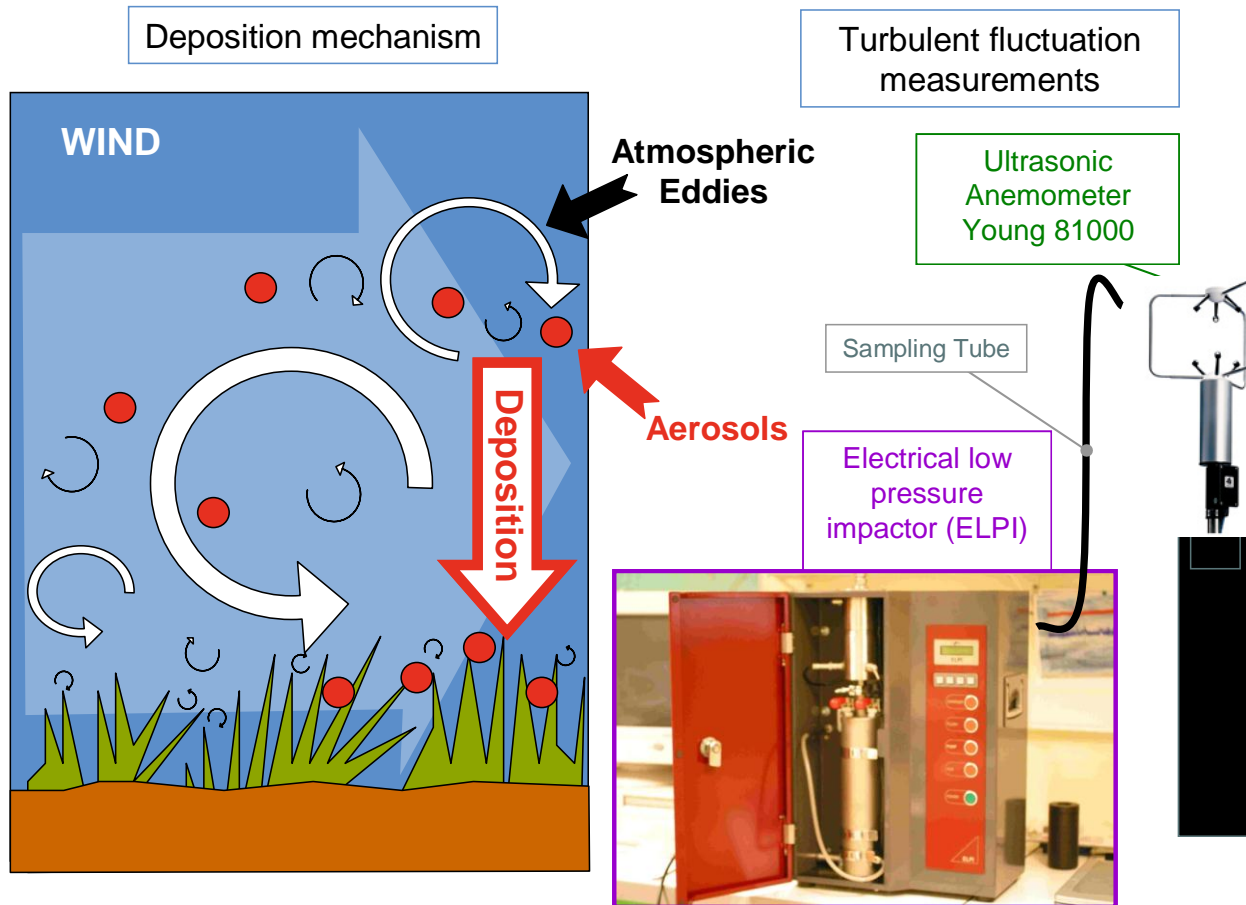

Limits of Eddy covariance method:

- ❑ Complicated processing data
- ❑ Strong Hypothesis on aerosol concentration and on the horizontal homogeneity of the substrate
- ❑ **Need of fast responses sensors (>> 1Hz)**

! Response time is different from data acquisition frequency

Context and objectives

The PPS a new promising fast aerosol sensor

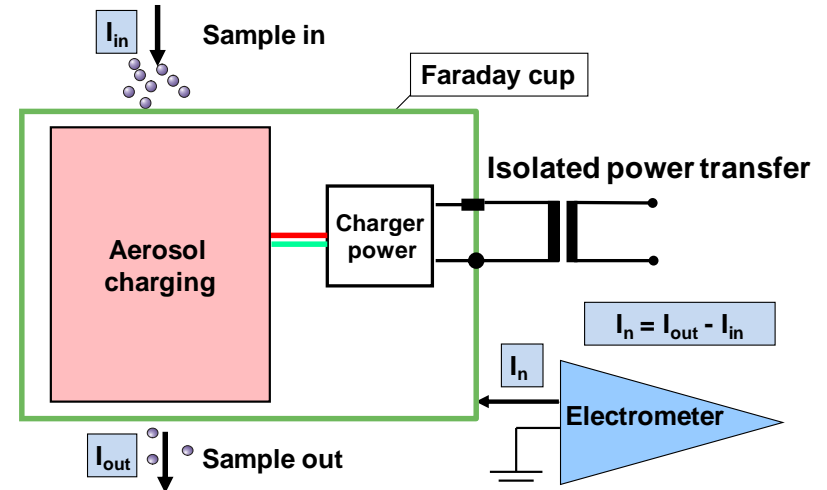
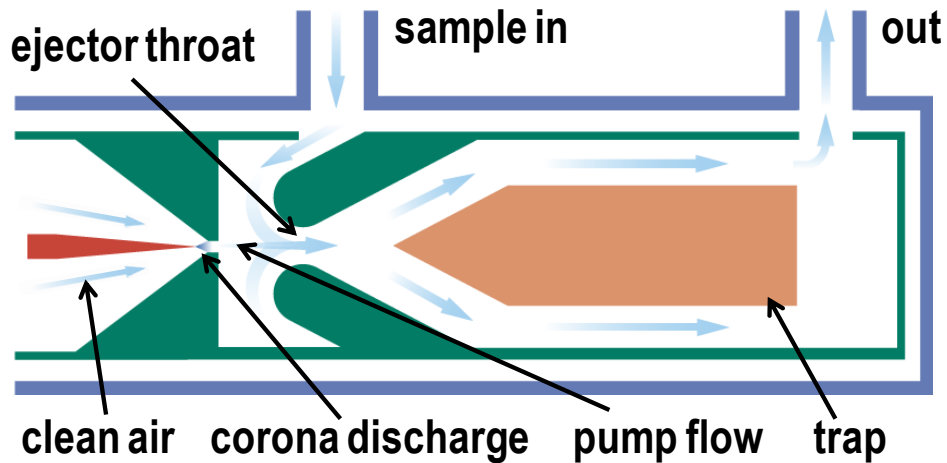

The PPS measure the electrical current carried by aerosol after particle charging by corona.

The measure is taken by aerosol current subtraction between inlet and outlet of a faraday cup, the originality of the system is to have a corona charging zone inside the aerosol faraday cup.

=> no collection of particle onto a filter

=> fast response time to changes in aerosol concentration

Aim of the study => laboratory tests of the PPS response for further outdoor applications with Eddy covariance method

Experimental method

Determination of the PPS response time => concentration step method with two synchronized electromagnetic valves switching system (classical method used by Quant *et al.* 1992, Hering *et al.* 2008...)

Determination of the PPS linearity => comparison with CPC measurement for different concentrations and size distributions

Reference aerosol production controlled by using spark discharge generator

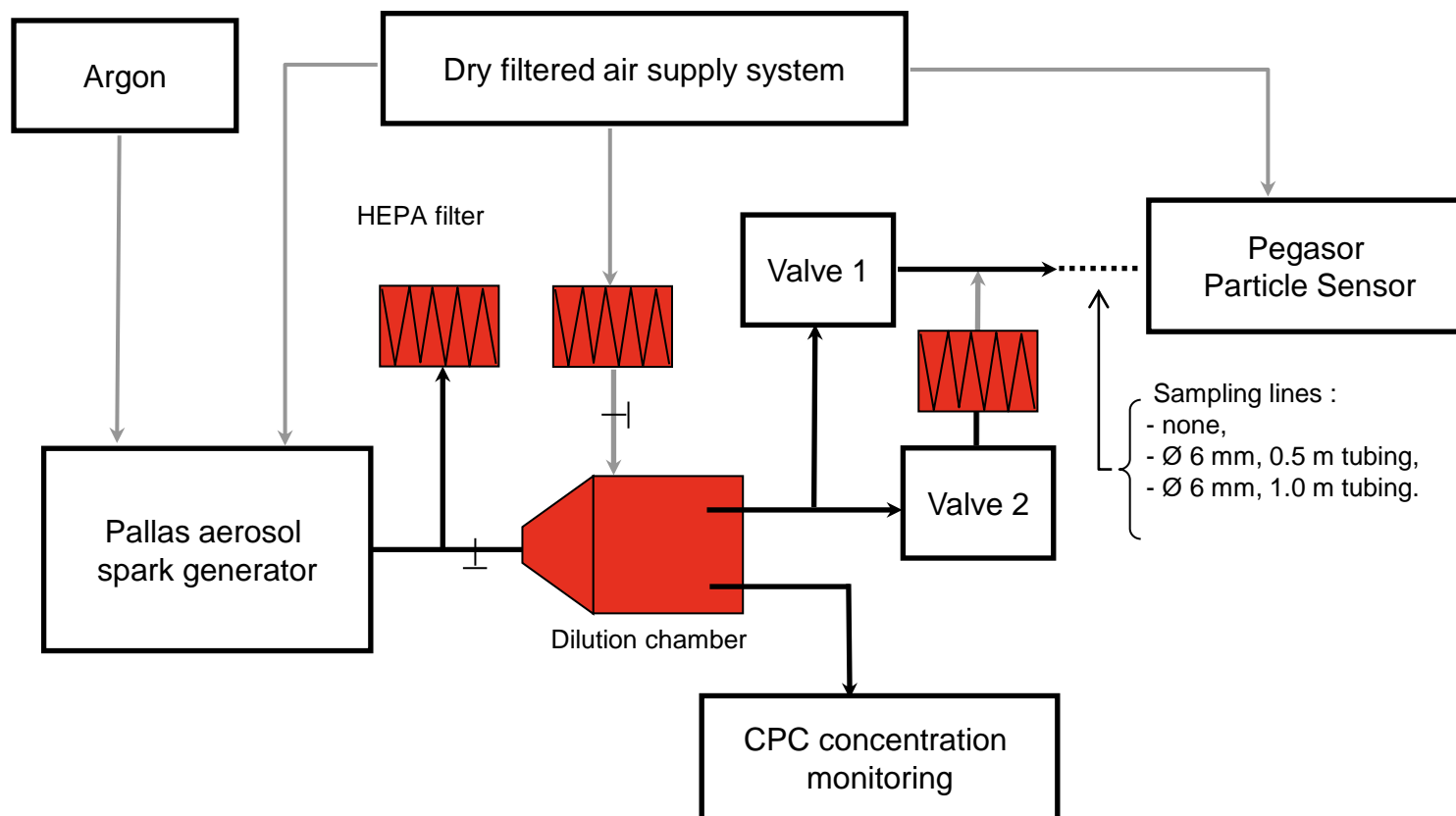

Experimental method

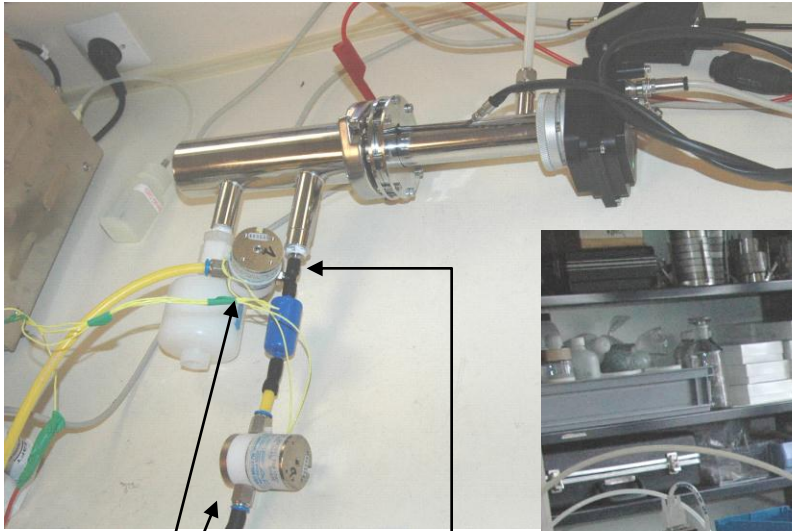

System of 2 synchronized electromagnetic valves switching system

Minimized death volume at the inlet



Experimental method

List of tests realized

Measurement of response time for different aerosol concentrations (10^3 p.cm⁻³ - 10^7 p.cm⁻³) and 3 size distributions (median diameters 20 nm to 100 nm):

=> study for step increase or step decrease,

=> study with 10 Hz or 100 Hz data acquisition frequency,

=> study of evolution of response time according to sampling line length.

Measurement of linearity of the PPS versus CPC for different aerosol concentrations and size distributions:

=> study of the response according to surface area concentration.

Experimental method

Characteristics of aerosols used

Aerosol size distributions measured with EEPs: Surface median diameters $D_{50S} = 29$ nm, 61 nm, 86 nm according to different spark generator configurations

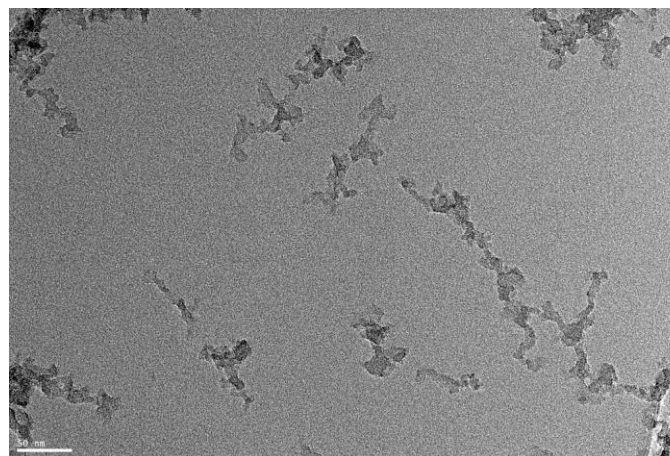
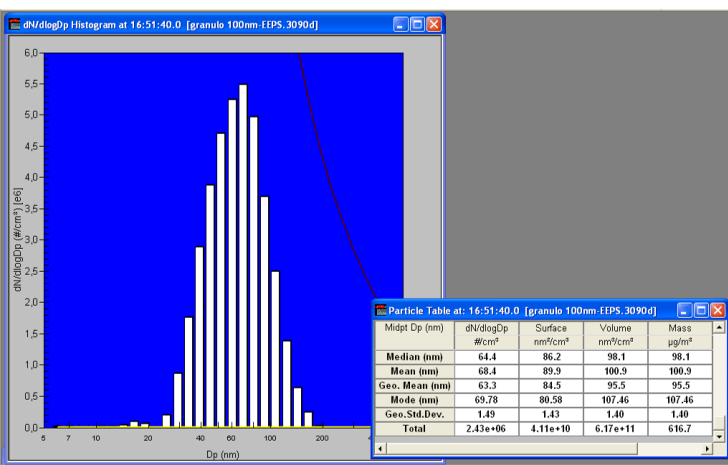
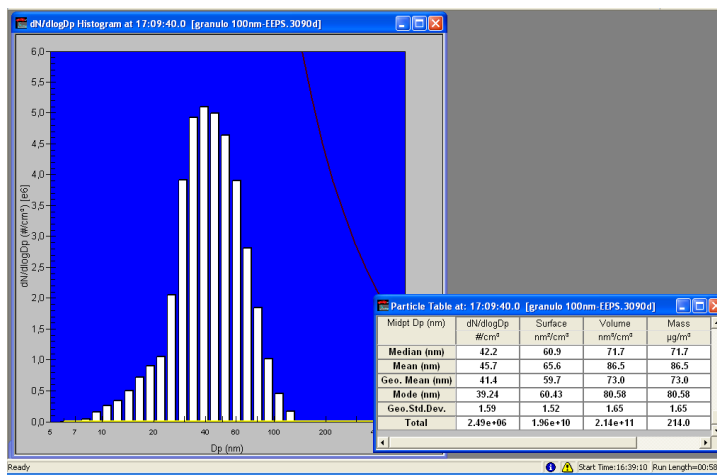
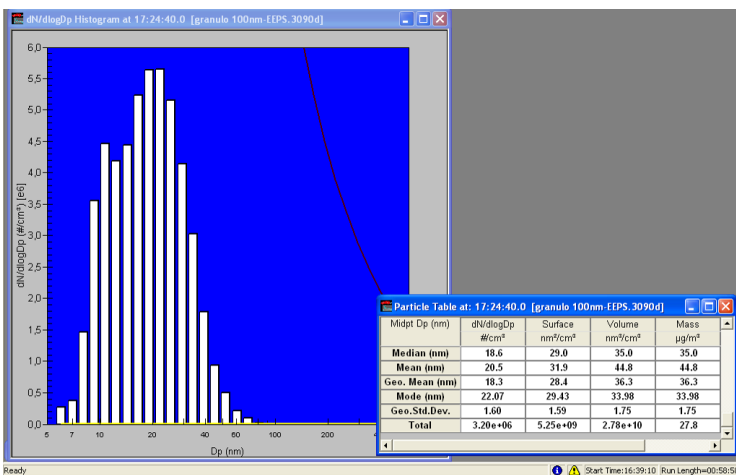

TEM micrograph of carbon aggregate particles

Example of results and data treatment

For each configuration the response time is determined by fitting the data with the classical exponential relationship:

$$C(t)/C_0 = 1 - \exp[-(t - t_0)/\tau]$$

where C_0 is the initial concentration (p.cm^{-3}), t_0 the time of the concentration step (s) and τ the response time (s).

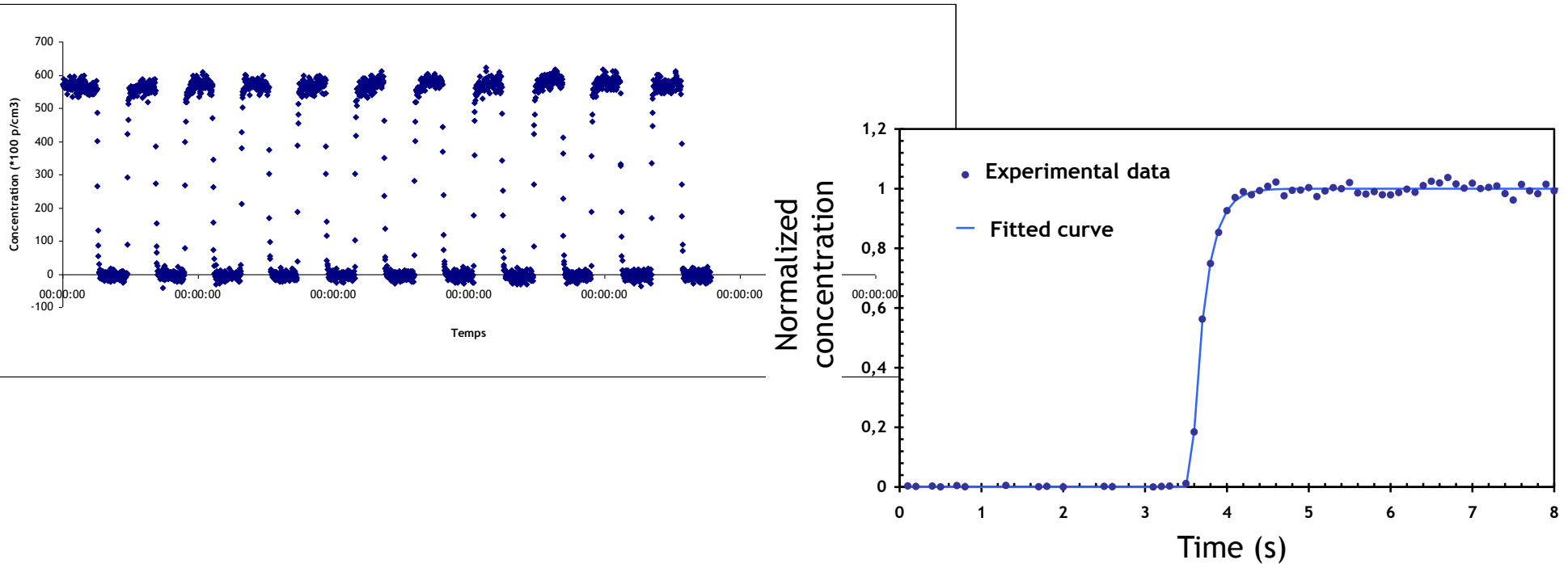

Example of results and data treatment

Measurement made for different aerosol concentrations

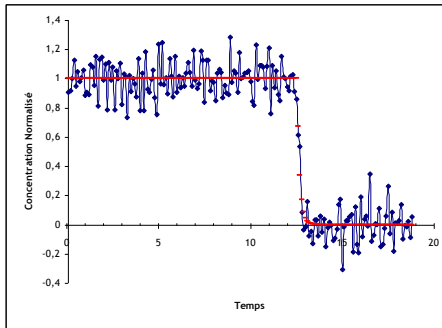

$$C = 4.3 \times 10^3 \text{ p/cm}^3, D_{50S} = 61 \text{ nm}$$

=> Data analysis is not relevant due to background noise at low level concentrations

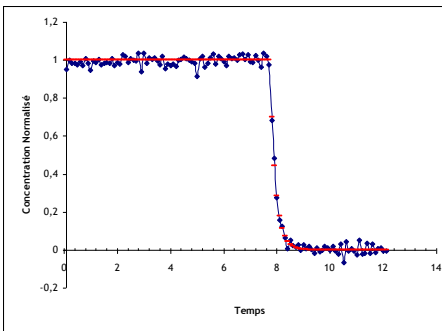

$$C = 3.5 \times 10^4 \text{ p/cm}^3, D_{50S} = 61 \text{ nm}$$

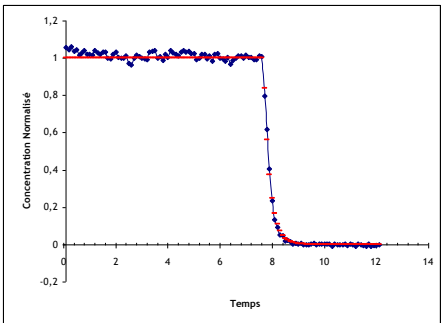

$$C = 1.5 \times 10^5 \text{ p/cm}^3, D_{50S} = 61 \text{ nm}$$

Example of results and data treatment

Measurement made for step increase or step decrease, example taken at 100 Hz data acquisition frequency

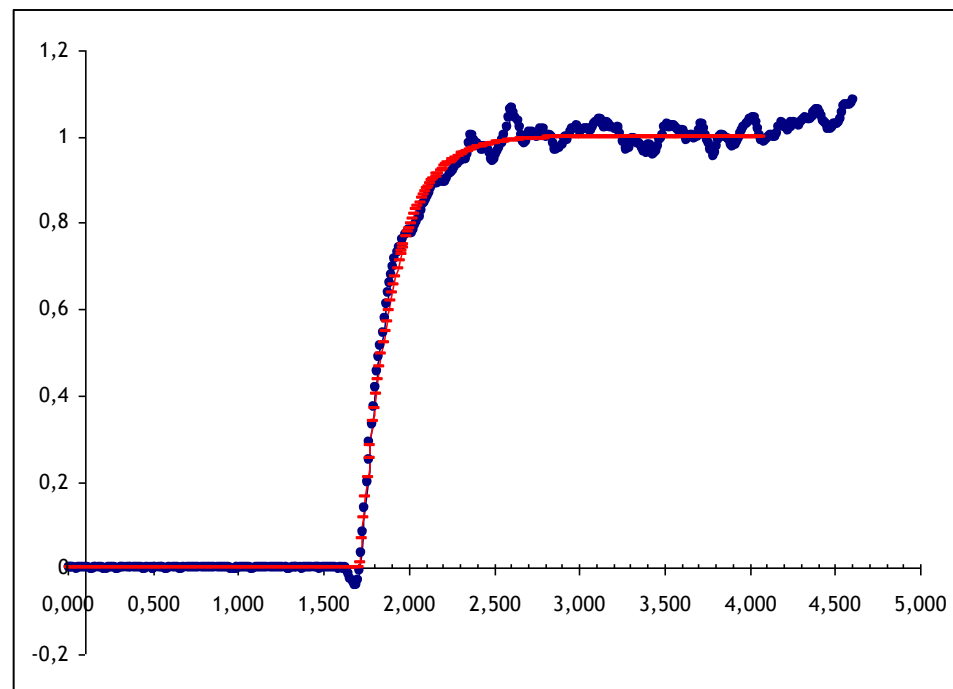
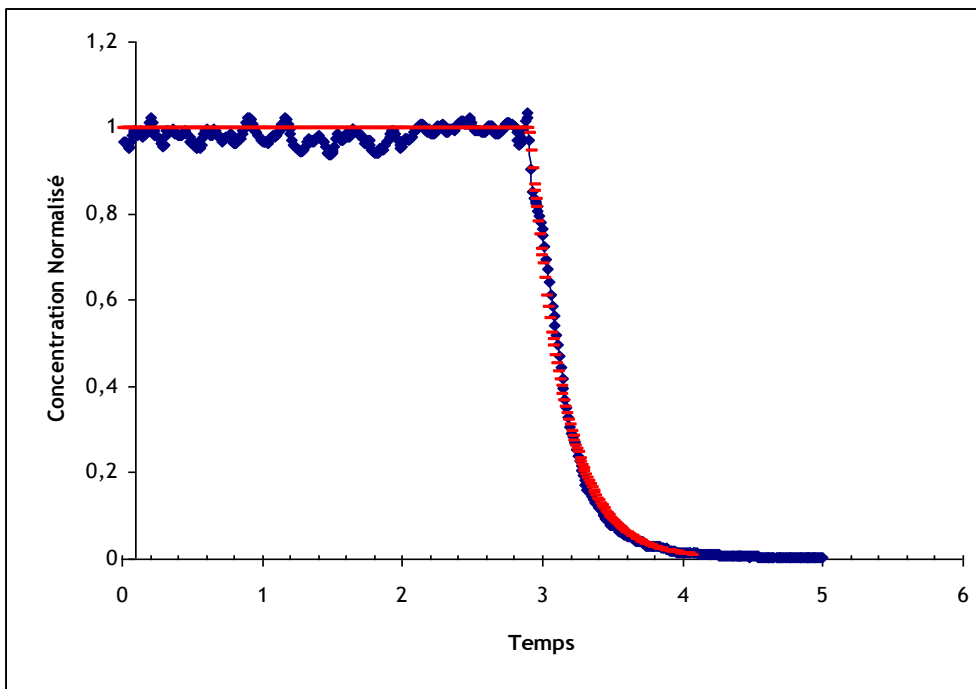

$$C = 1,5 \cdot 10^6 \text{ p/cm}^3, D_{50S} = 86 \text{ nm}$$

Synthesis of results at 10 Hz and 100 Hz

Measurements made at 10 Hz

| Median diameter (nm) | Concentration (p/cm ³) | Mean response time, step increase (s) | 2*standard deviation (s) | Mean response time, step decrease (s) | 2*standard deviation (s) |
|----------------------|------------------------------------|---------------------------------------|--------------------------|---------------------------------------|--------------------------|
| 29 | 1.50E+05 | 0.187 | 0.022 | 0.228 | 0.023 |
| 29 | 3.30E+04 | 0.154 | 0.073 | 0.166 | 0.039 |
| 61 | 1.50E+05 | 0.183 | 0.033 | 0.249 | 0.027 |
| 61 | 3.50E+04 | 0.187 | 0.027 | 0.242 | 0.027 |
| 86 | 1.30E+05 | 0.173 | 0.027 | 0.247 | 0.035 |
| 86 | 3.70E+04 | 0.187 | 0.031 | 0.218 | 0.016 |

Measurements made at 100 Hz

| Median diameter (nm) | Concentration (p/cm ³) | Mean response time, step increase (s) | 2*standard deviation (s) | Mean response time, step decrease (s) | 2*standard deviation (s) |
|----------------------|------------------------------------|---------------------------------------|--------------------------|---------------------------------------|--------------------------|
| 86 | 1.80E+05 | 0.170 | 0.039 | 0.237 | 0.018 |
| | 1.50E+06 | 0.180 | 0.021 | 0.248 | 0.005 |
| | 1.80E+06 | 0.173 | 0.012 | 0.243 | 0.012 |

Each mean response time is calculated with 5 concentration steps analysis

Synthesis of results at 10 Hz and 100 Hz

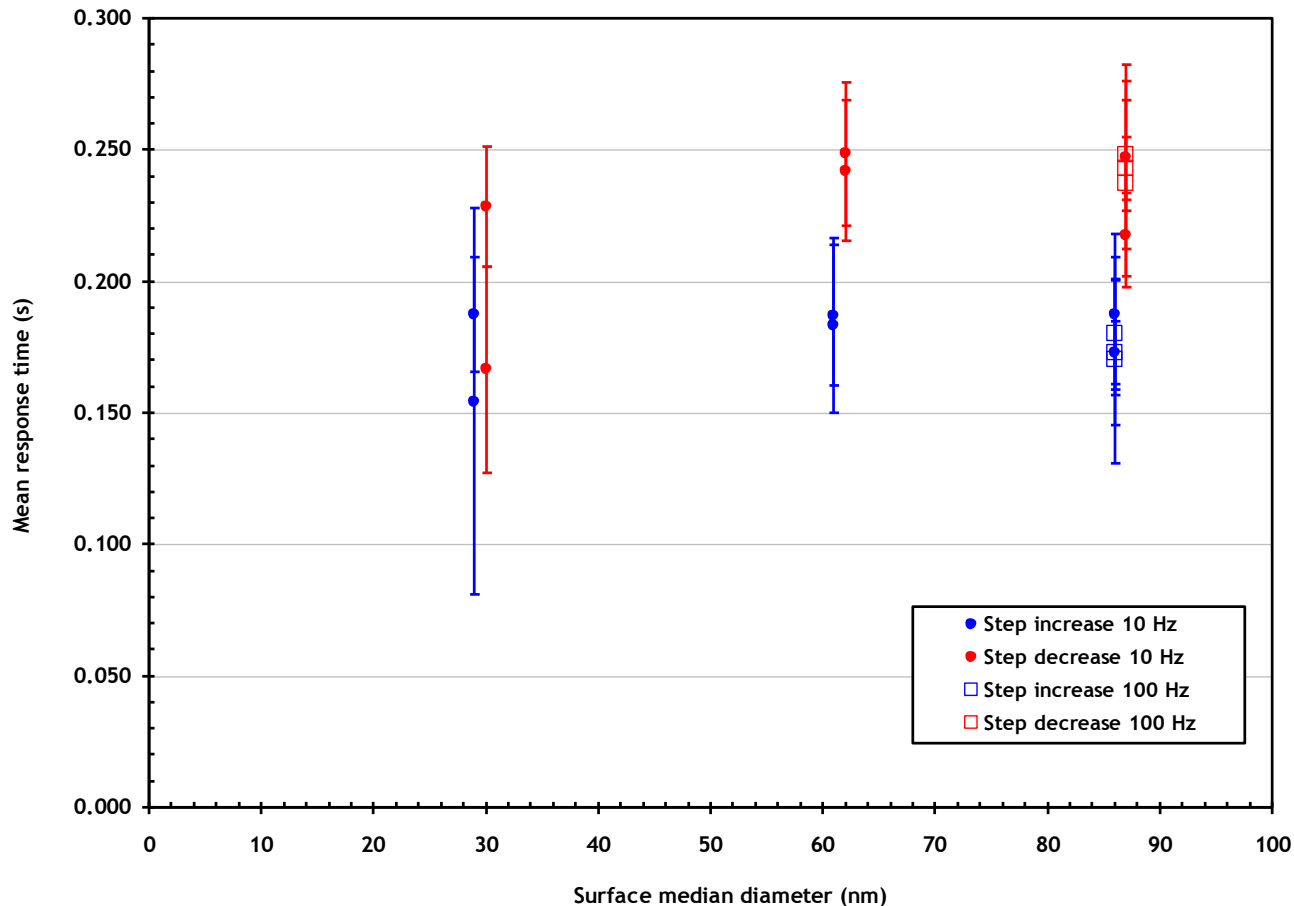

No effect of aerosol size distribution or concentration on the response time of the PPS.

No effect of data acquisition frequency on the response time.

Significant difference between response time for concentration step increase and step decrease.

Synthesis of results according to sampling lines

| Median diameter (nm) | Sampling line length (m) | Concentration (p/cm ³) | Mean response time, step increase (s) | 2*standard deviation (s) | Mean response time, step decrease (s) | 2*standard deviation (s) |
|----------------------|--------------------------|------------------------------------|---------------------------------------|--------------------------|---------------------------------------|--------------------------|
| 86 | 0 | 3.20E+05 | 0.192 | 0.014 | 0.249 | 0.031 |
| | 0.5 | | 0.219 | 0.037 | 0.315 | 0.073 |
| | 1 | | 0.237 | 0.009 | 0.403 | 0.059 |

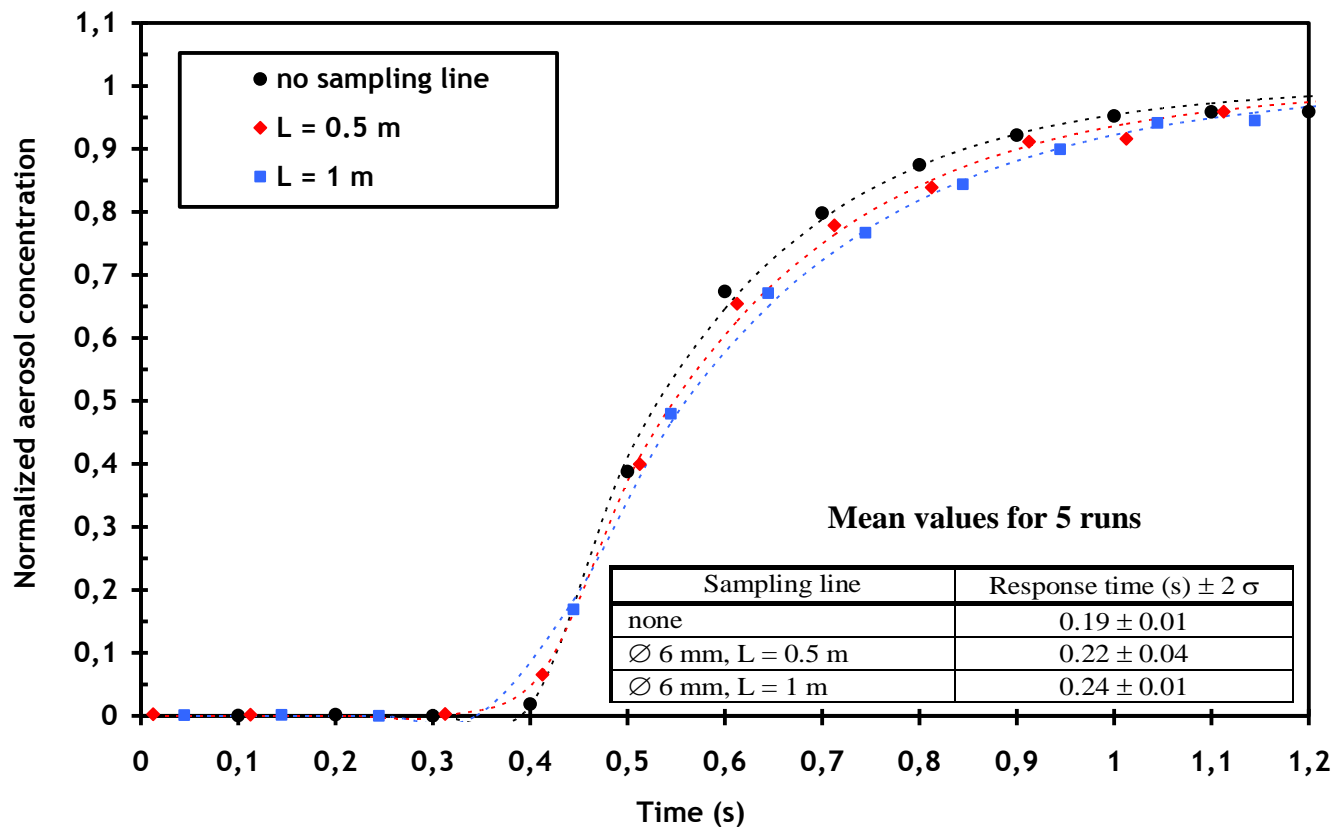

=> Results show very short response times around 0.2 s and logical small increases with sampling line lengths due to laminar flow profile.

Synthesis of results on PPS linearity versus CPC

- ❑ The concentrations given by PPS and CPC (Grimm 1.403) are compared for different aerosol size distributions.
- ❑ Each concentration (CPC and Pegasor) is calculated with 2 min average period.

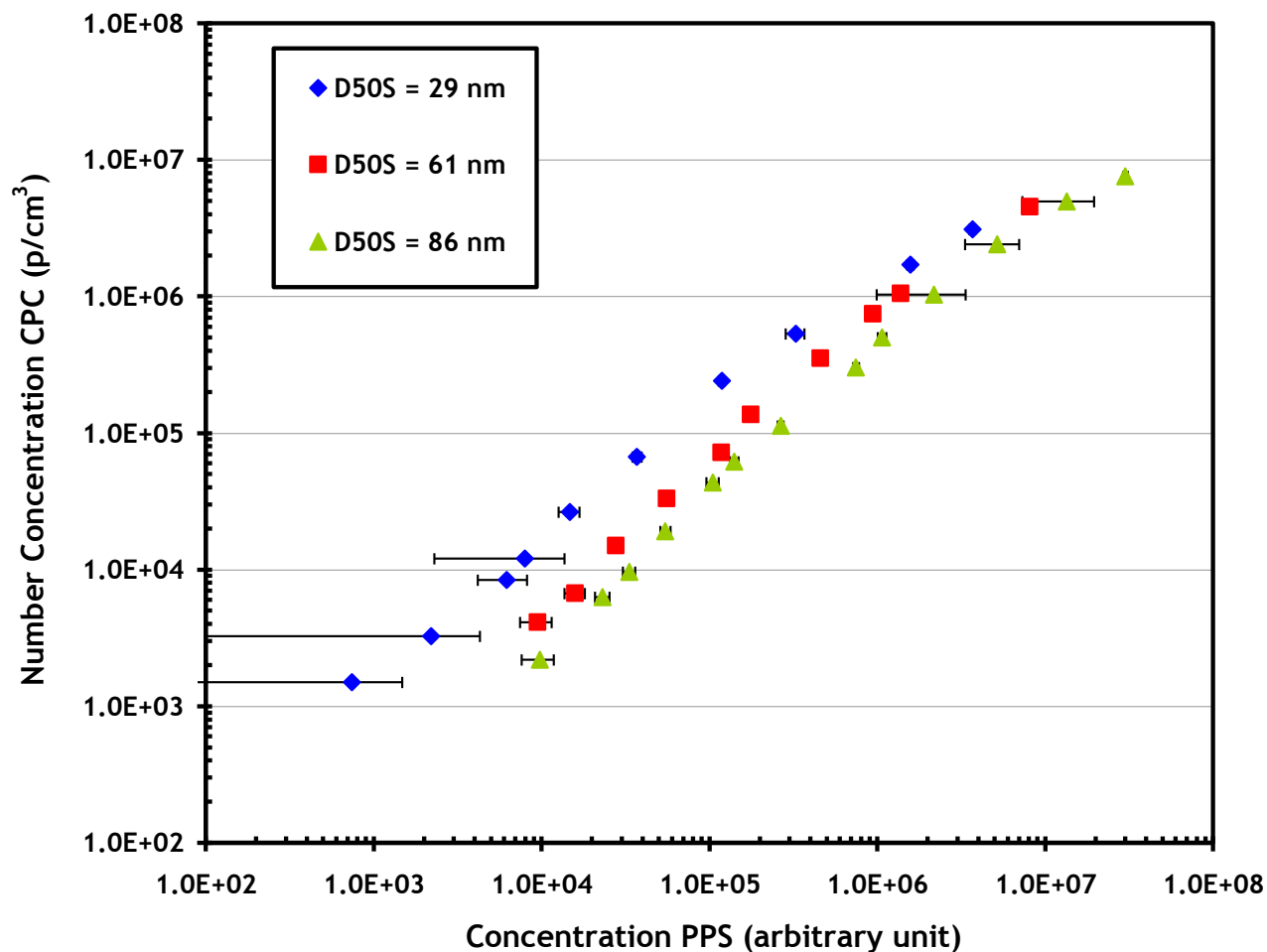

Synthesis of results on PPS linearity versus CPC

- The concentration given by PPS is normalized thanks to active surface area of the aerosol in the transition regime: Active surface area (dp) $\propto \left(\frac{dp}{d_0}\right)^{X(dp)}$ with $X(dp)=1.39$ for the transition regime (Jung et Kittelson, 2005)

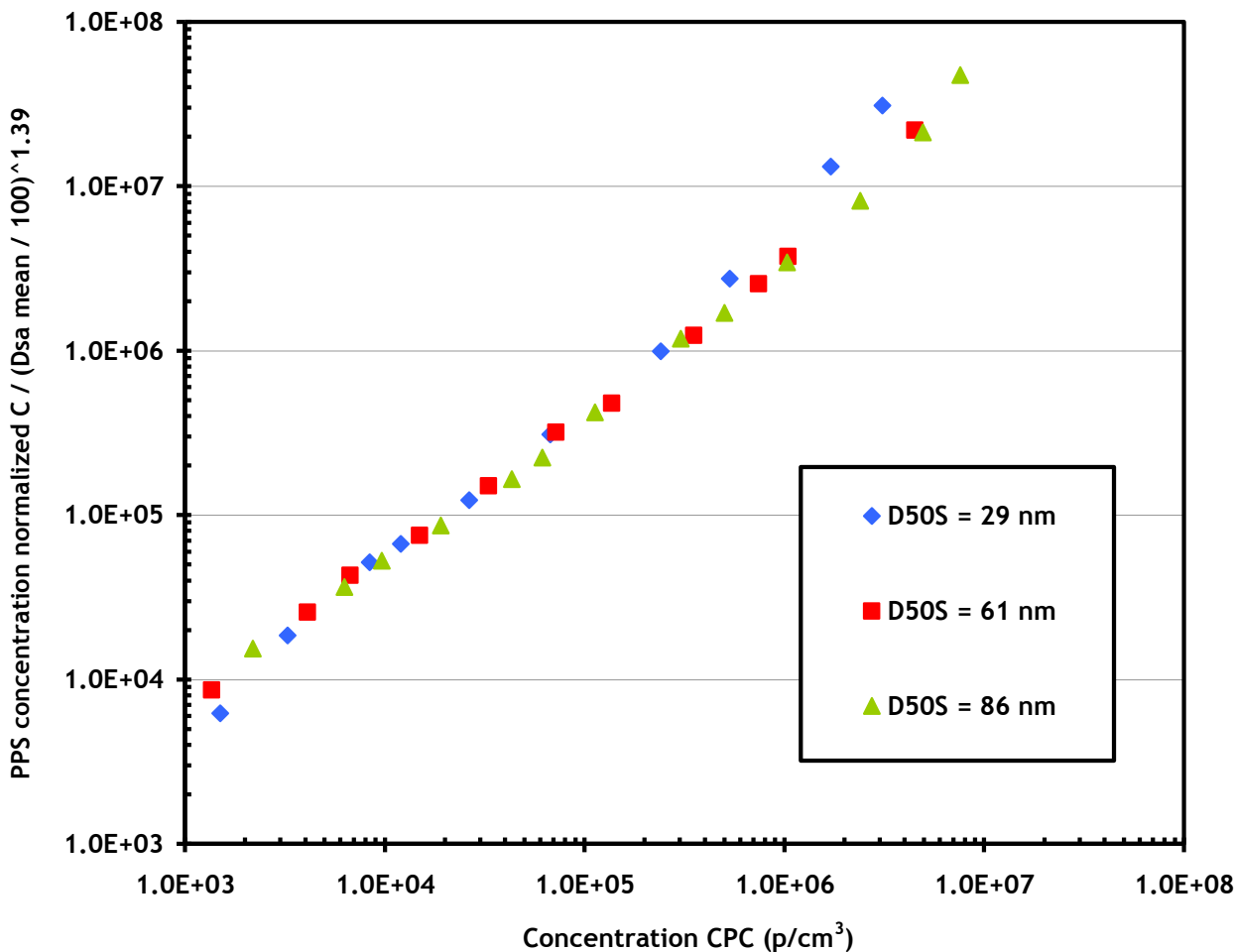

=> Results show good linearity of the PPS in terms of active surface area concentration independently of the particle size distribution

Conclusion and perspective

- ❑ PPS show good repeatability of response time measurement
- ❑ The characteristic response time is ~ 0.18 s for concentration step increase and ~ 0.23 s for step decrease (no explanation for this difference at the moment !)
- ❑ The response times with 10 Hz or 100 Hz data acquisition frequency are similar
- ❑ The response time logically increase with sampling line length, 0.18 s to 0.24 s with 1 m length (tube diameter 6 mm)
- ❑ The linearity of the PPS in terms of number concentration depend on the aerosol size distribution
- ❑ The PPS show a good linearity when the response is expressed in terms of active surface area concentration

=> Further developments are needed in order to decrease the response time down to 0.1 s in order to use the Eddy covariance technique in a wide range of atmospheric situation: a high flow PPS is still under study