

In-Use NTE PM Measurement Methodology using an In-Line, Real-Time Exhaust PM Emissions Sensor

Marc C. Besch¹, Arvind Thiruvengadam¹, Hemanth Kappanna¹,
Alessandro Cozzolini¹, Peter Bonsack¹, Daniel K. Carder¹,
Juha Tikkanen², Mridul Gautam¹

Department of Mechanical and Aerospace Engineering
West Virginia University

¹Pegasor Ltd, Tampere, Finland

Content

- Particle Sensor Technology
- NTE Measurement Methodology
- Experimental Setup
- Results and Discussion
 - Engine Dynamometer Results
 - Chassis Dynamometer Results
 - (On-Road Testing Results)
- Conclusions

Introduction

- In-use Emissions Compliance Measurements/Testing:
 - Quantification of PM mass emitted during Not-to-Exceed (NTE) events
 - Establishing mass reference for aerosol in real-time
- Other Fields of Application
 - On-board Diagnostics Applications
 - PM Sensor for Development and Implementation of DPF Regeneration Strategies
 - Combustion Research and Engine Base Calibration Applications

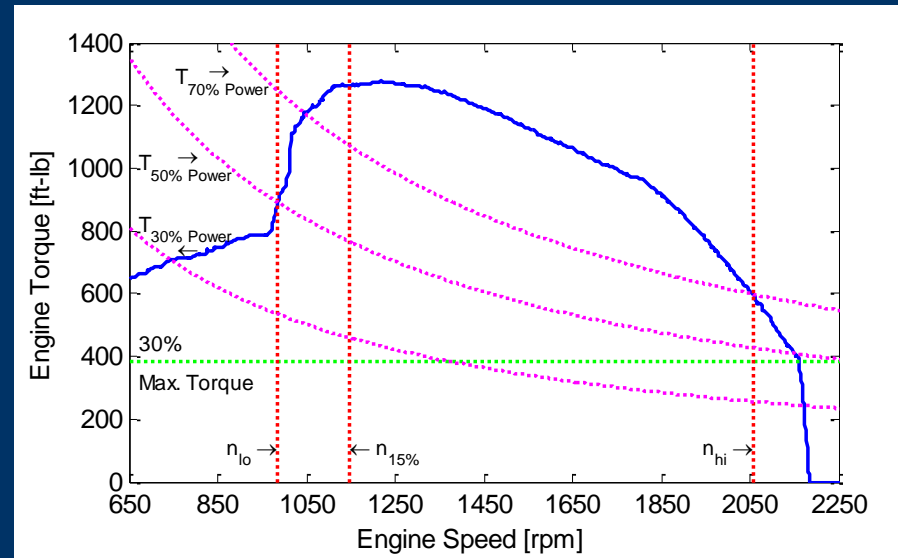

Engine lug-curve form Mack MP7 – 355E (MY 2004)



Sensor - Description of Technology

- Measurement based on escaping current principle

PPS Installation on Exhaust:

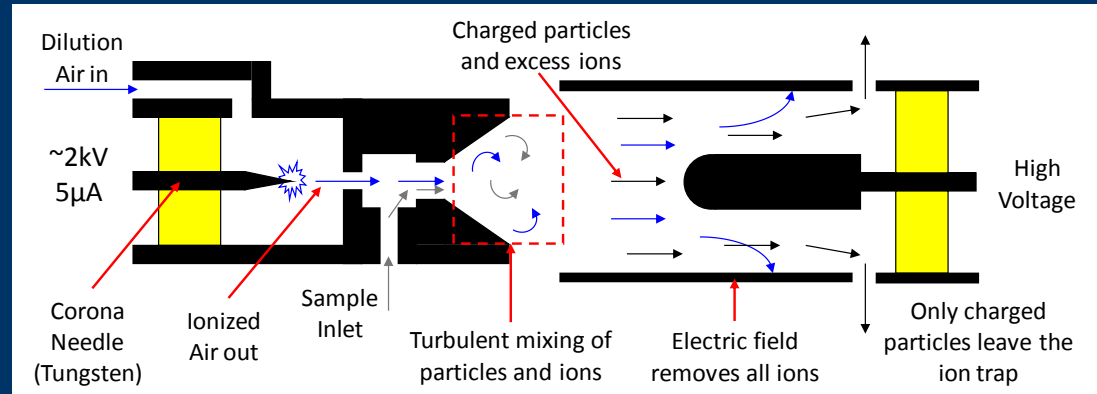
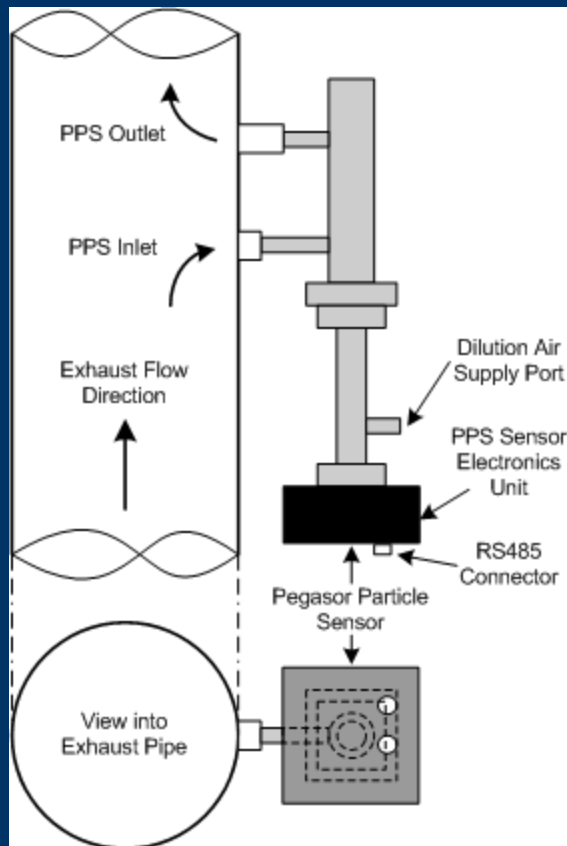

Picture provided by Pegasor Oy

Advantages:

- Real-time
- Continuous operation
- No PM sample collection
- No external dilution of exhaust needed

Operational Parameters:

- Sampling rate up to 100 Hz
- Sensor output can be calibrated to $[\text{mg}/\text{m}^3]$ or $[\#/ \text{m}^3]$

NTE In-use Measurement Method

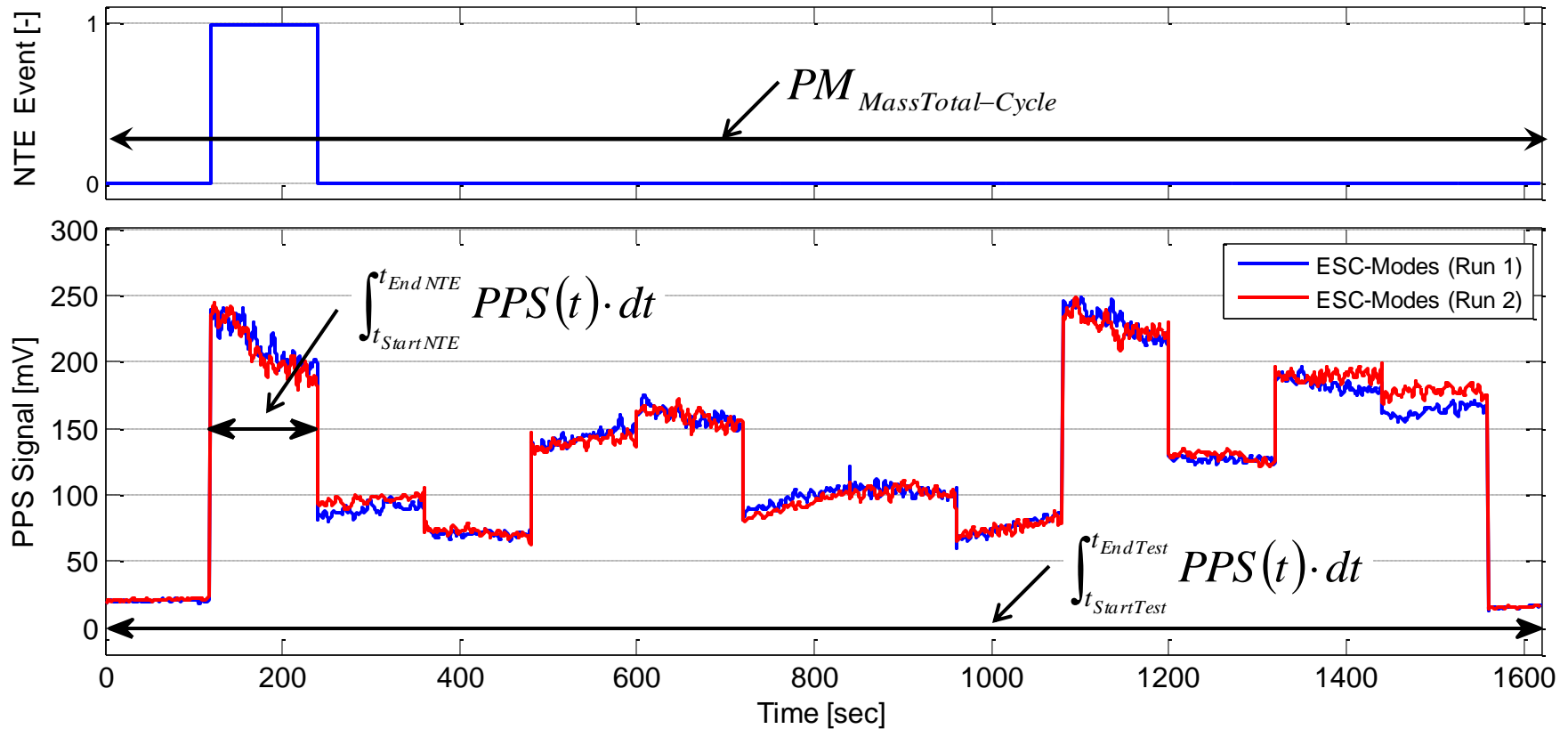

Calculation of PM mass [mg] during NTE event:

$$PM_{MassNTE} = PM_{RatioPPS} \cdot PM_{MassTotal-Cycle}$$

$PM_{MassTotal-Cycle}$ = TPM from gravimetric filter sample

$$PM_{RatioPPS} = \frac{\int_{t_{StartNTE}}^{t_{EndNTE}} PPS(t) \cdot dt}{\int_{t_{StartTest}}^{t_{EndTest}} PPS(t) \cdot dt}$$

Experimental Setup

Engine Dynamometer:

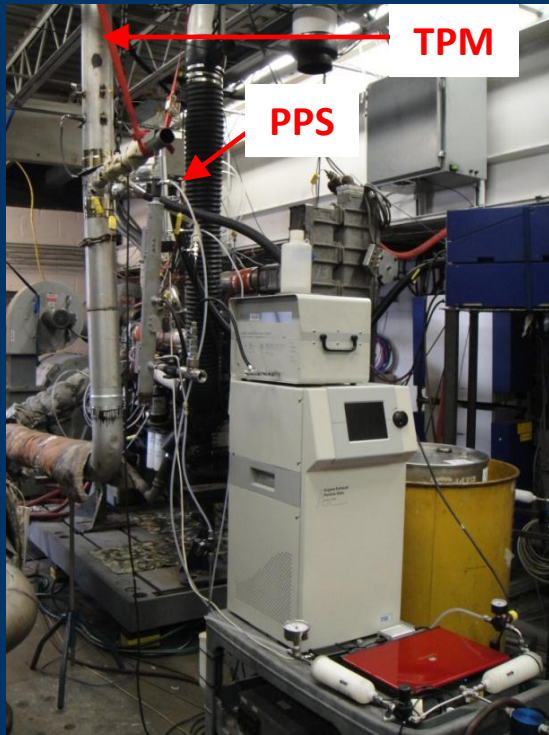

- Full flow dilution tunnel (CVS-SSV)
- 11L Mack MP7 - 355E (2004)
- No aftertreatment system
- EEPS (TSI, Model 3090)
- CPC (TSI, Model 3025)
- MSS (AVL, Model 483)
- Intake Air Flow Measurement
- Proportional Flow TPM Sampling

Chassis Dynamometer:



- Full flow dilution tunnel (CVS-SSV)
- 6.6L Duramax - GMC4500 (2004)
- GVW ~ 12'000 pounds
- Diesel Oxidation Catalyst (DOC)
- Exhaust Flow Measurement
- Horiba OBS and Sensors SEMTECH
- Proportional Flow TPM Sampling

On-Road Testing:



- 6.6L Duramax - GMC4500 (2004)
- GVW ~ 12'500 pounds
- Diesel Oxidation Catalyst (DOC)
- Exhaust Flow Measurement
- Horiba OBS and Sensors SEMTECH
- Constant Flow TPM Sampling

Setup - Engine Test Cell/Chassis Dynamometer

$$C_{CVS} = C_{Exh} \cdot \frac{1}{DR_{CVS}}$$

$$\alpha_{Loss} = f(L, D, \dot{V}, \Delta T)$$

(Not applied to presented results)

$$C_{Filter} = C_{CVS} \cdot \frac{1}{DR_{Sec PM}}$$

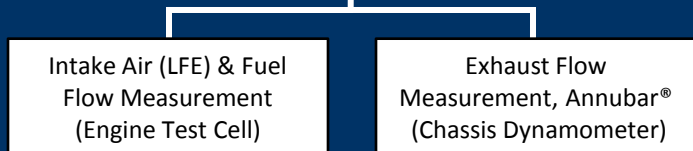
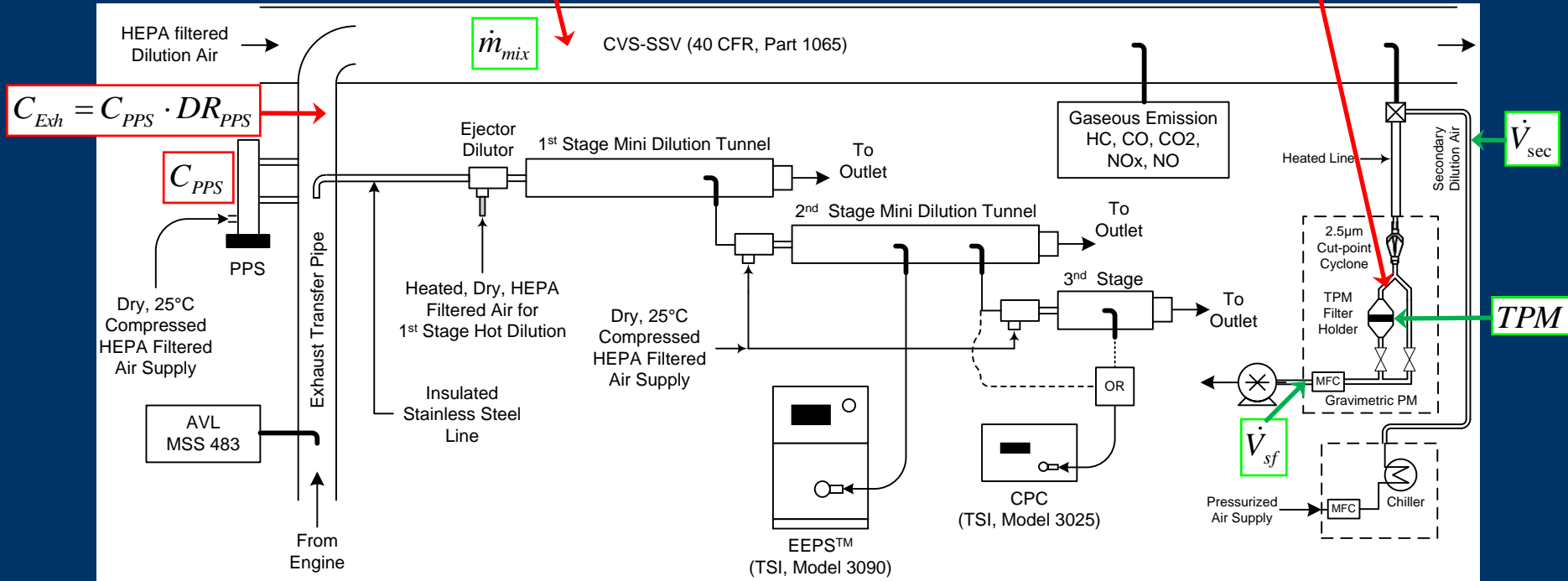

$$\dot{V}_{Intake} \text{ \& } \dot{m}_{fuel}$$

$$\dot{V}_{Exh}$$

$$DR_{PPS} = 0.0053 \cdot [psi] + 1.3082$$

$$DR_{CVS} = \frac{\dot{m}_{mix}}{\dot{m}_{Exh}}$$

$$DR_{Sec PM} = \frac{\dot{V}_{sf}}{\dot{V}_{sf} - \dot{V}_{sec}}$$

Dilution System for EEPS and CPC:

Stage	Temperature	DR
1st Stage	Hot, ~ 130C	DR = 6
2nd Stage	Cold, ~ 25C	DR = 24
3rd Stage **	Cold, ~ 25C	DR = 8

** Only for CPC

Setup - On-Road Testing

$$C_{Exh} = C_{PPS} \cdot DR_{PPS}$$

$$C_{Filter} = C_{CVS} \cdot \frac{1}{DR_{Sec PM}}$$

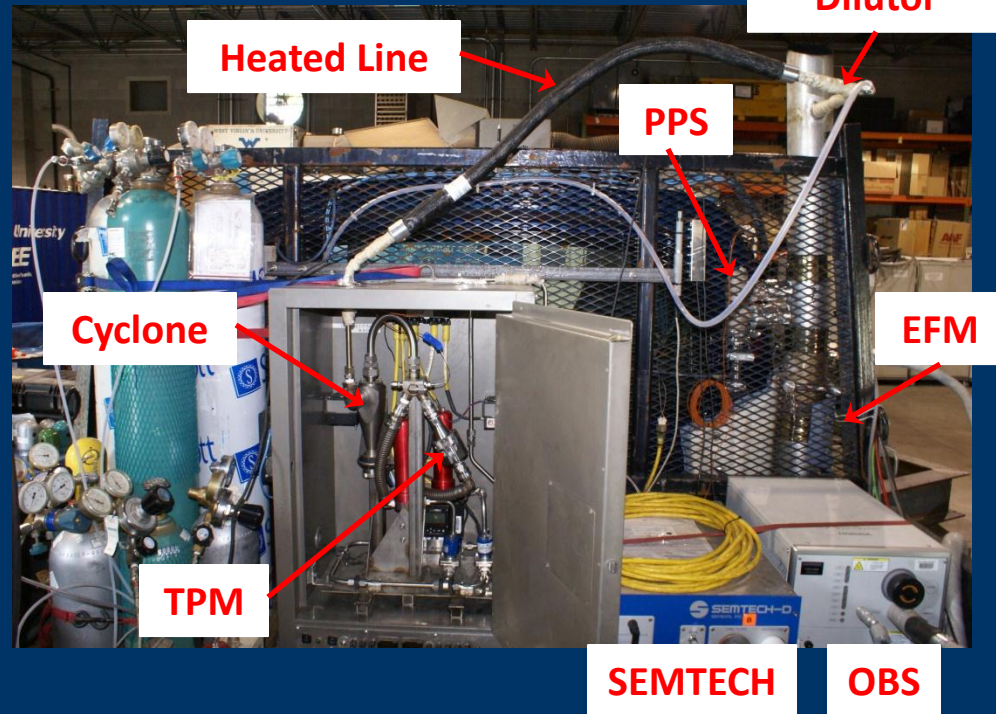
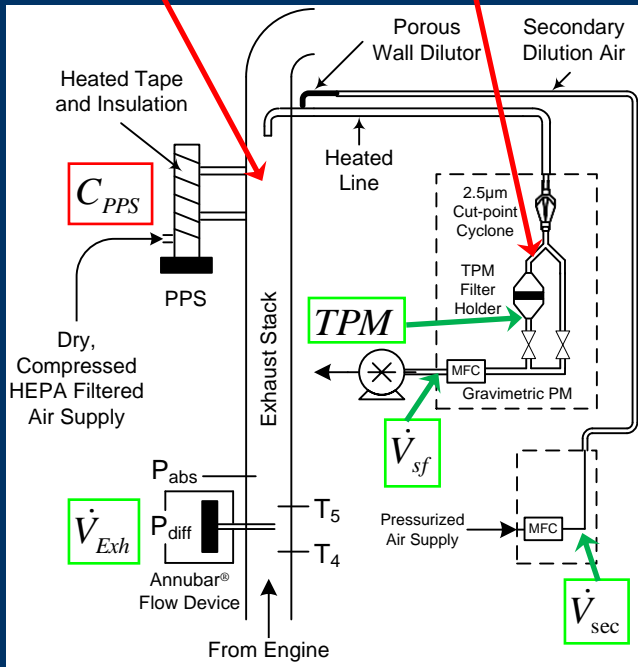

$$\alpha_{Loss} = f(L, D, \dot{V}, \Delta T) \text{ (Not applied to presented results)}$$

$$DR_{PPS} = 0.0053 \cdot [psi] + 1.3082$$

$$DR_{Sec PM} = \frac{\dot{V}_{sf}}{\dot{V}_{sf} - \dot{V}_{sec}}$$

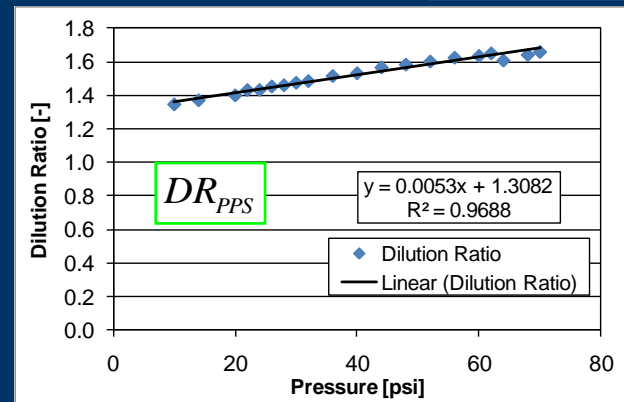

Results - Engine Test Cell

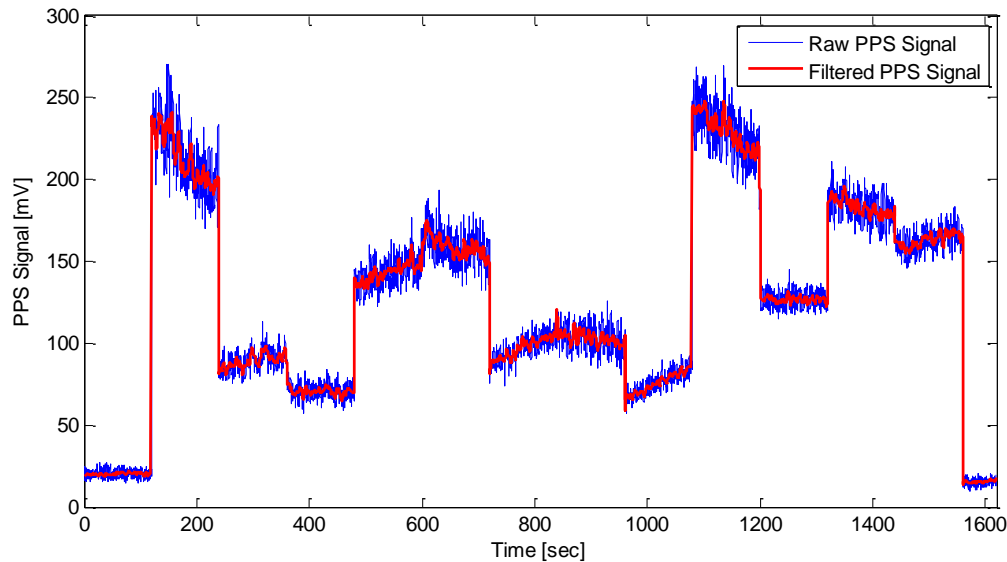

➤ PPS Signal Filtering/Smoothing:

- Savitzky-Golay (Least-Squares Smoothing Filters)
- *For Steady-State:*
 - Frame Size - 8.1 sec
 - Filter Order - 3
- *For Transient Cycle:*
 - Frame Size - 2.1 sec
 - Filter Order - 5

➤ Instrument Grounding at On-Road

PPS Concentration as calculated at different locations in the measurement stream between PPS sample cell (blue line) and gravimetric filter face

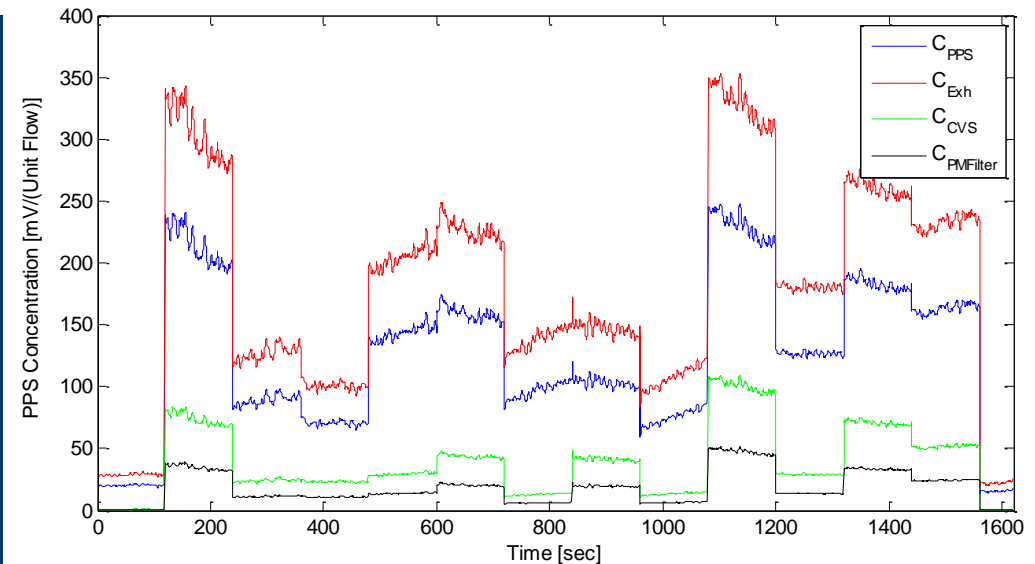

Results - Engine Test Cell (ESC)

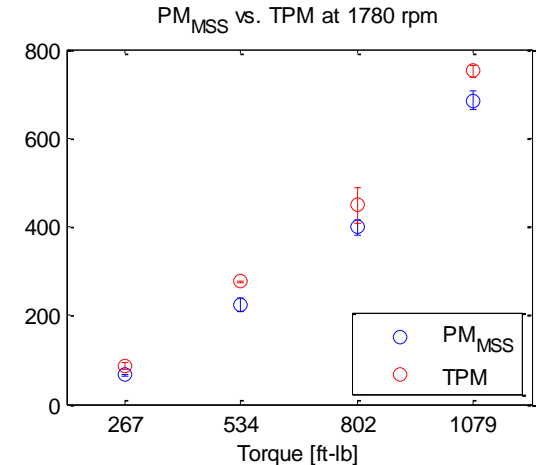
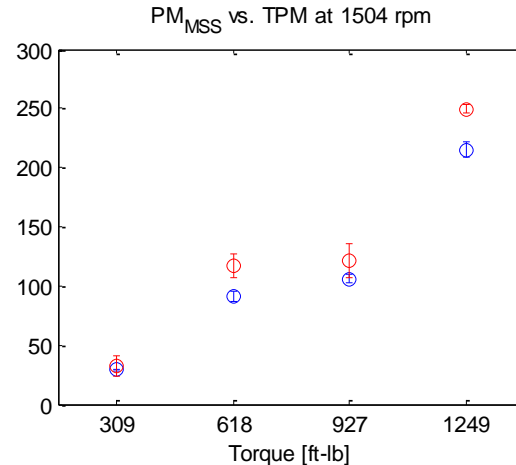
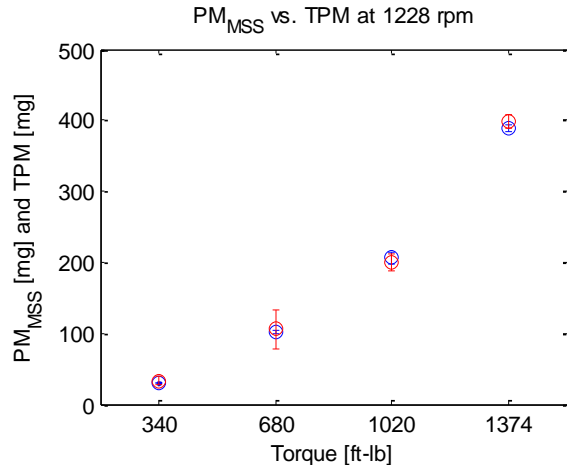
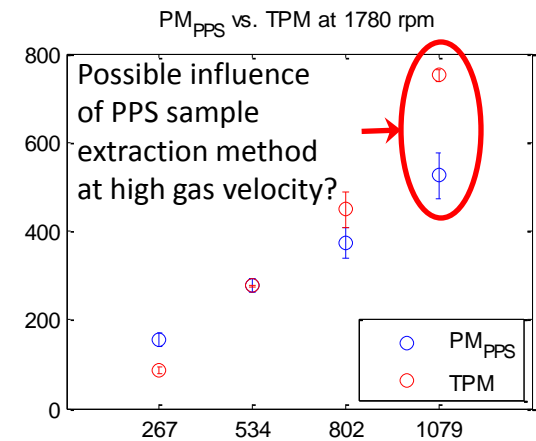
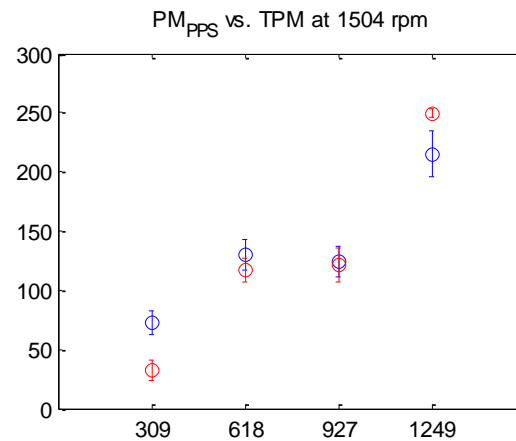
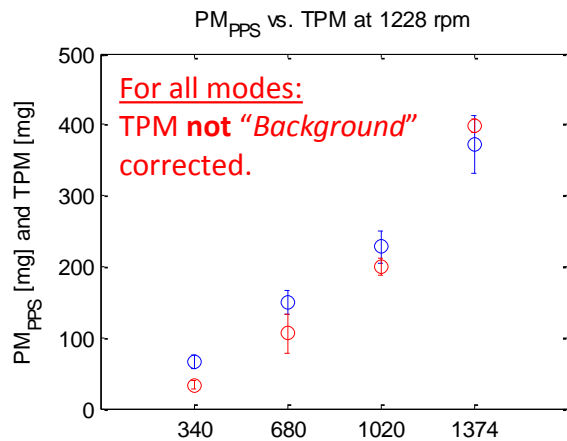

- AVL MSS => Corrected for temperature influence and thermophoretic losses
- TPM includes absorbed SOF => PPS and AVL do not measure this fraction => Possible correction based on HC

Results - Chassis Dynamometer

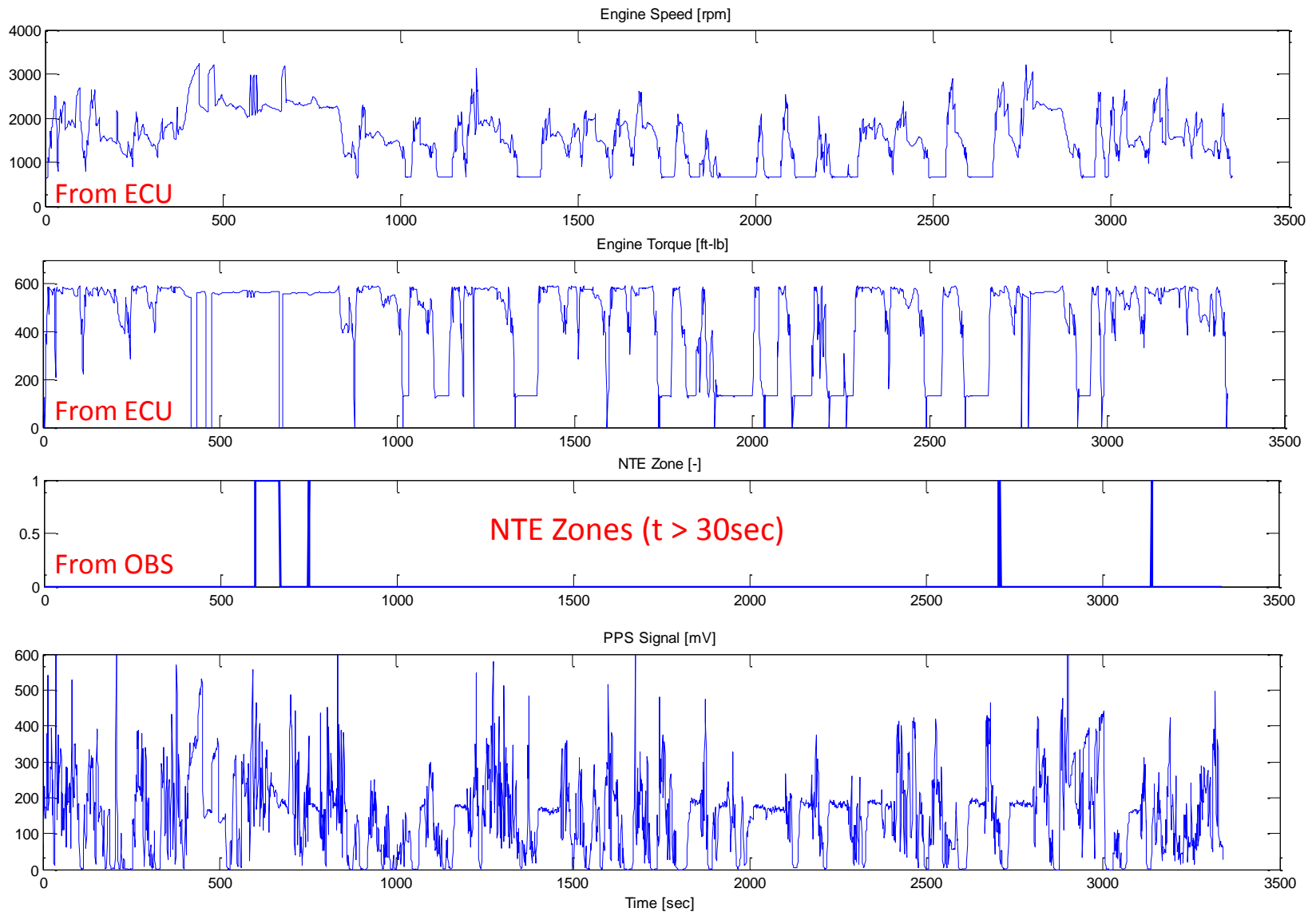

Conclusion and Outlook

- Response of PPS to PM emissions during the transient test cycle (FTP) was similar to that of EEPS (R^2 Value: 0.8969) and AVL MSS (R^2 Value: 0.8479).
- Development of NTE In-use Measurement Method using the PPS Signal to calculate PM during NTE events.
- Demonstration of this method based on engine dynamometer experiments => PPS-Method captures general trends.
 - Possible influence of high exhaust flow rates on sample extraction efficiency
 - Accounting for particle losses within transfer pipes
 - Influence of SOF on gravimetric filter weight
- Chassis Dynamometer and On-Road analysis is ongoing.

Thank You for Your Attention

Results - PPS vs. AVL MSS, Engine-out

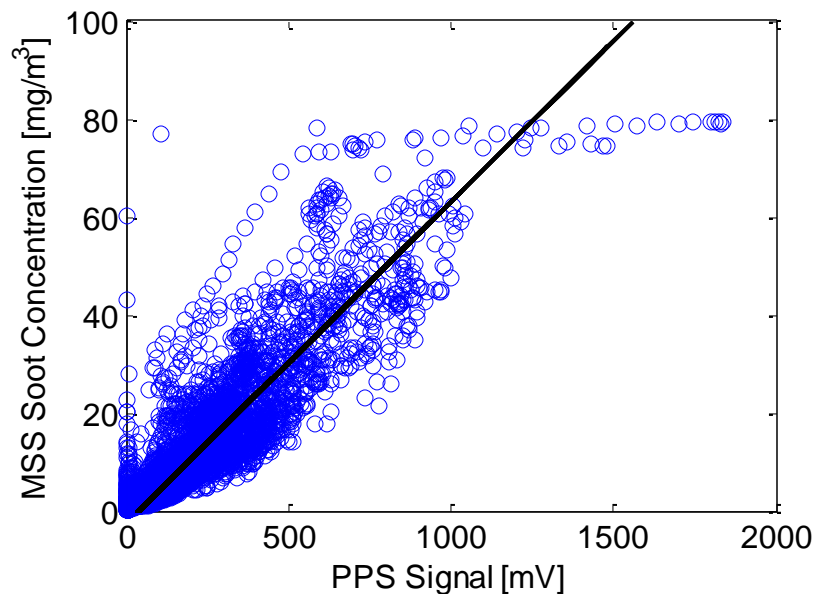
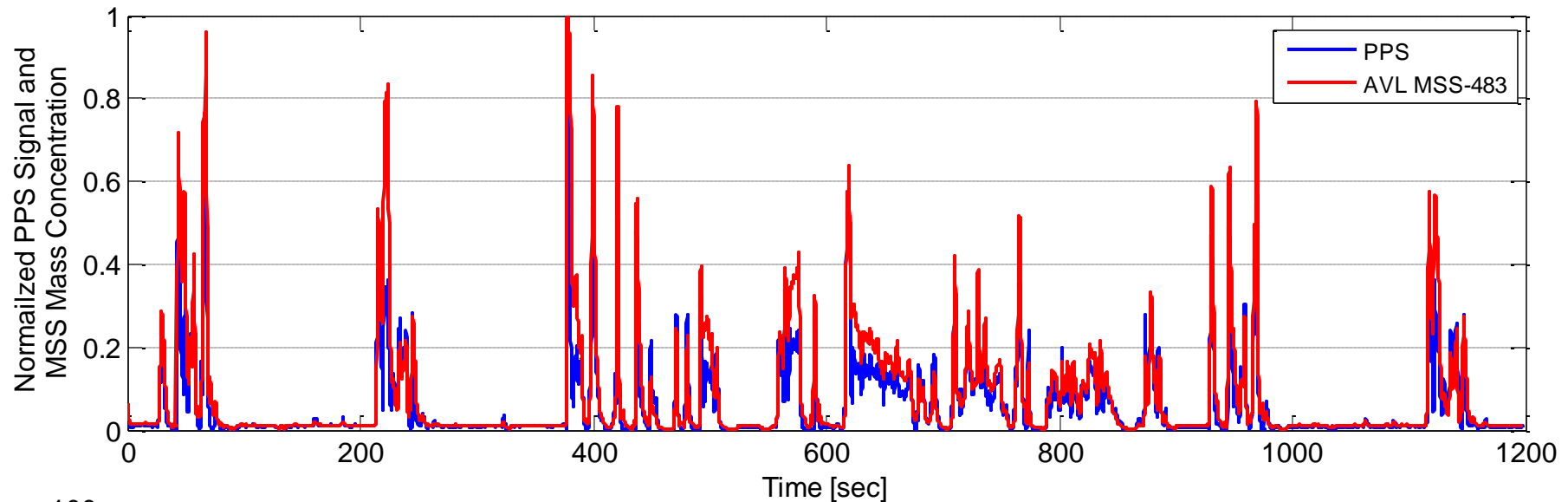

- Engine: Mack MP-7 (MY 2004)
- No aftertreatment, engine-out measurement
- FTP-Cycle, Dynamometer

Linear Regression Coefficients:
(Least Squares Method)

$$\text{PPS [mg/m}^3\text{]} = 0.1787 + 0.0581 * \text{PPS [mV]}$$

R-Square Value: 0.8479

Results - PPS vs. EEPS, Engine-out

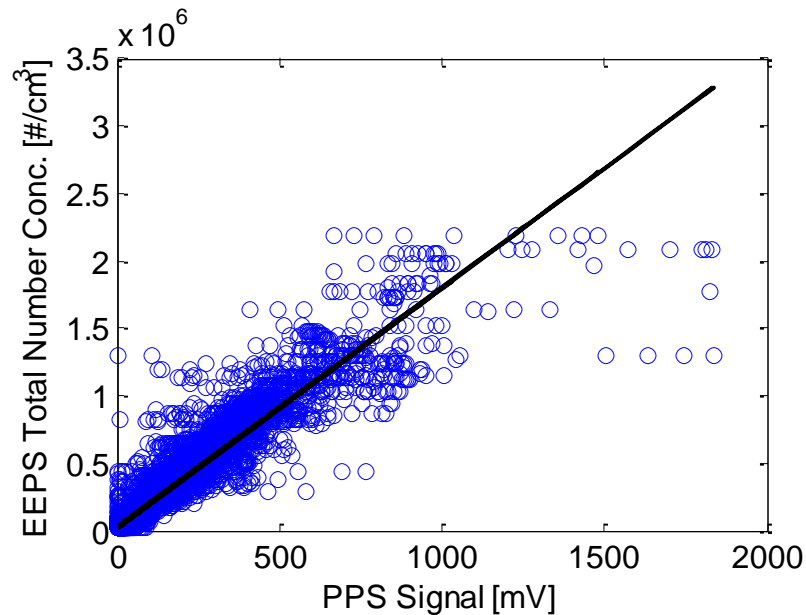
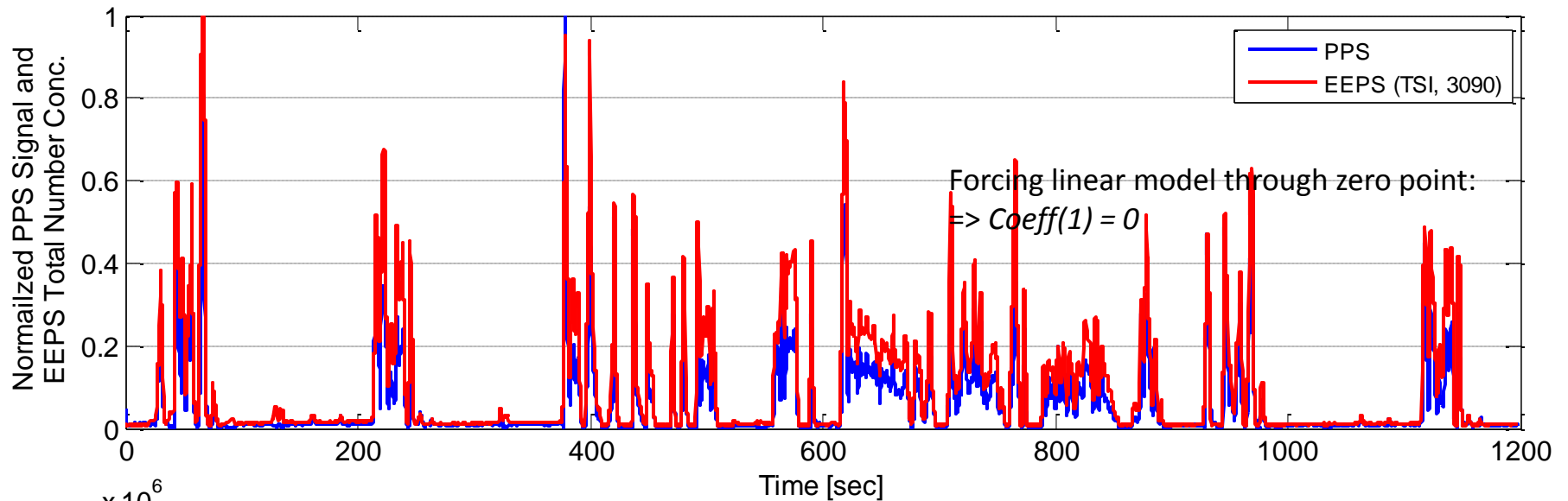

- Engine: Mack MP-7 (MY 2004)
- No aftertreatment, engine-out measurement
- FTP-Cycle, Engine Dynamometer

Linear Regression Coefficients:
(Least Squares Method)

$$\text{PPS} [\#/m^3] = 2.244E4 + 1.777E3 * \text{PPS} [\text{mV}]$$

R-Square Value: 0.8969

Sensor – Operational Parameters, cont'

- Low temperature version max 250 °C
- High temperature version max. 850 °C
- High concentration version 10 $\mu\text{g}/\text{m}^3$ -250 mg/m^3
- High sensitivity version $\sim 1\mu\text{g}/\text{m}^3$
- Sensor dimensions 20-40 mm diameter, 100-200 mm long – to be decided together with customers
- Electronics; 80x40x20 mm^3
- Sensor output calibrated to mg/m^3 or #-particles/ cm^3
- Sensor is installed outside the tailpipe with only inlet and outlet in the tailpipe
- Environmental conditions up to 85 degrees C, IP 45

Sensor - Description of Technology Cont'd

